

REVISIONS			
Rev.	Modification	Date	Done By

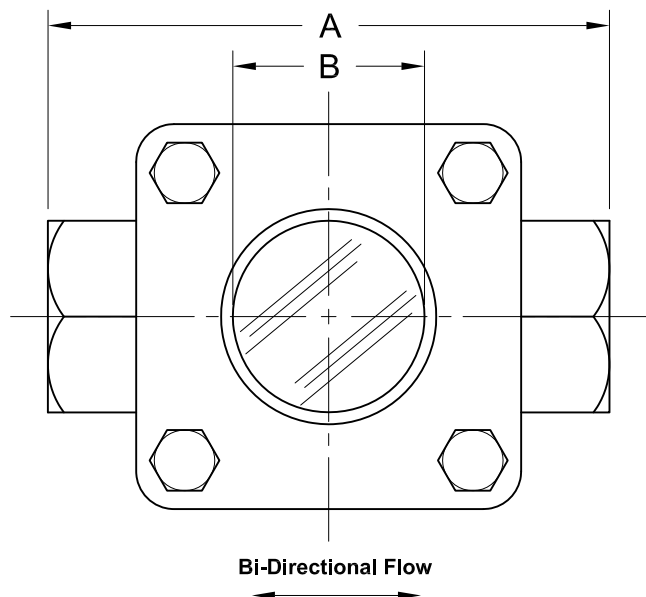

ASME CLASS 150 SERVICE PRESSURE/TEMP. RATINGS
 *Limited to Gasket & Glass Material

Temp. (°F)	Pressure (PSIG)		
	CS	316SS	Bronze
-20 to 100	285	275	225
150	270	255	225
200	260	235	210
250	245	225	195
300	230	215	180
350	215	205	165
400	200	195	150
450	185	180	N/R
500	170	170	N/R

*Consult Sales for Higher & Lower Temps.

BILL OF MATERIALS
 * - Denotes an Optional, Non-Standard Material

No.	Name of Part	Qty.	Material	Max. Temp. (°F)	Material Grade	
011	Body	1	Carbon Steel		ASTM A216 WCB	
			Bronze			
			316SS		ASTM A351 CF8M	
007	Gasket	2	Neoprene	250		
			Gylon®	500	Gylon® 3545	
			*Viton®	350		
			*Graphite	500		
			*Non Asbestos	500	D-7301	
			*Buna-N	250		
009	*OPT. Shield*	2	*Mica V4		Not Pictured	
048	Lens	2	Tempered Boro.	500		
001	Retainer	2	Carbon Steel		ASTM A36	
			*316SS		ASTM A240	
	004	Nut	4	Carbon Steel		ASTM A563
				*316SS		ASTM A194-8M
	008	Cushion	2	Graphite	500	
137	Stud	4	Carbon Steel		ASTM A449	
			*316SS		ASTM A193-8M	
163	Nameplate	1	SS			

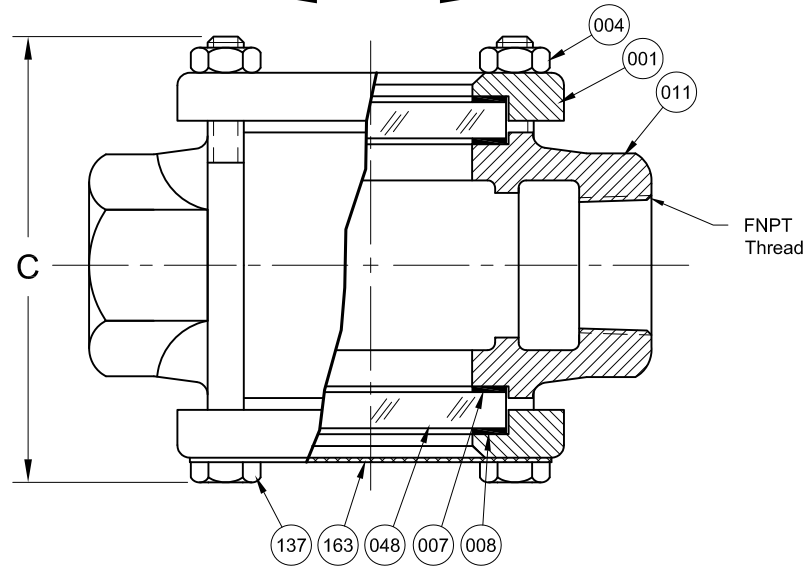

PRODUCT SPECIFICATIONS

FNPT Size	A		B		C ₁		Weight	
	In.	mm.	In.	mm.	In.	mm.	lbs.	kg.
2-1/2	8-1/2	216	3-3/4	95	8-1/8	206	40	18.1
3	8-1/2	216	3-3/4	95	8-1/8	206	38	17.2

KEY NOTES

- Standard Bolt Length Shown in "C" Dimension (±1/8")
- Limited to Glass & Gasket Ratings

S14TD Series Configuration Choices:

Reference the Series S14TD Model Number Matrix on our Website or Inquire with our Sales Team

Gylon® is a Registered Trademark of Garlock Sealing Technologies
 Viton® is a Registered Trademark of the Chemours Company

JOHN C ERNST LLC.		www.johnernst.com 21 Gail Ct. Sparta, N.J. USA	
Series S14TD SFI - Plain 150# Threaded - 2-1/2" & 3"			
Sheet 1 of 1	Drawn By: WAS	Tolerances, unless otherwise noted Dec.: ± Frac.: ± Ang.: ±	
Scale: NTS	Approved By: JCW	Size: A	
Date: 11-OCT-18	Dwg. No.: SC2.S14TD.00.0.0		Rev.: -