

REVISIONS			
Rev.	Modification	Date	Done By
0	Original	3/16/2016	WAS
A	Weights Modified	10/12/2018	WAS

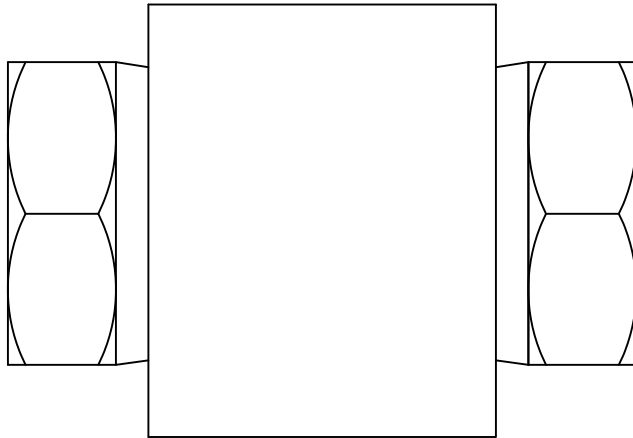

Bi-Directional Flow

PRODUCT SPECIFICATIONS											
FNPT Size	A		B		C		D		Weight		Rating
	In.	mm.	In.	mm.	In.	mm.	In.	mm.	lbs.	kg.	PSIG
1/8	3-3/16	81	1-1/4	32	2-1/8	54	2-7/32	56	1.6	0.7	125
1/4	3-3/16	81	1-1/4	32	2-1/8	54	2-7/32	56	1.6	0.7	125
3/8	3-3/16	81	1-1/4	32	2-1/8	54	2-7/32	56	1.4	0.6	125
1/2	3-13/16	97	1-1/2	38	2-7/16	62	2-7/16	62	2.0	0.9	125
3/4	3-13/16	97	1-1/2	38	2-7/16	62	2-7/16	62	1.9	0.9	125
1	4-3/8	111	1-5/8	41	3-1/8	79	3	76	3.6	1.6	125
1-1/4	4-3/8	111	1-5/8	41	3-1/8	79	3	76	3.1	1.4	125
1-1/2	4-5/8	117	1-5/8	41	4	102	3-13/16	97	6.1	2.8	125
2	4-5/8	117	1-5/8	41	4	102	3-13/16	97	4.7	2.1	125

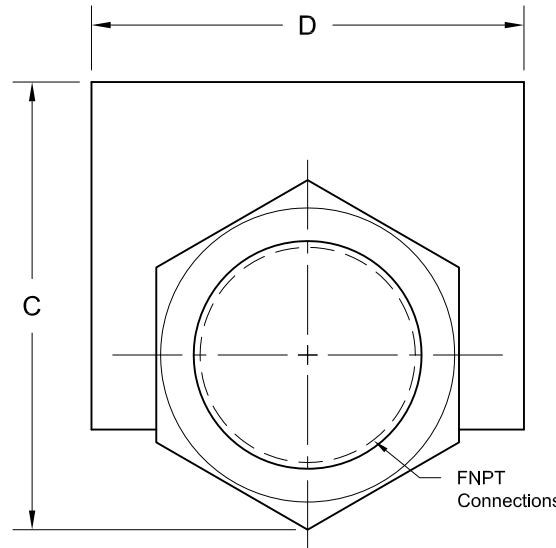
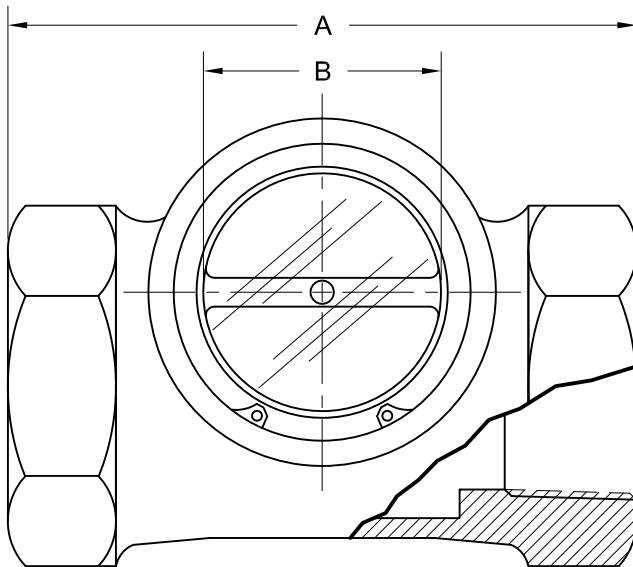

BILL OF MATERIALS				
	Name of Part	Qty.	Material	Max. Temp. (°F)
Wetted	Body	1	Bronze	
	Gasket	2	Buna	200
	Lens	2	Tempered Soda Lime	
Non Wetted	C-Clip	2	Steel	

\*Note: Replacement Parts are Not Available

**S11 Series Configuration Choices:**

Reference the Series S11 Model Number Matrix on our Website or Inquire with our Sales Team

<b>JOHN C ERNST LLC.</b>		www.johnernst.com 21 Gail Ct. Sparta, N.J. USA	
Series S11 Threaded SFI - Double Window - Plain			
Sheet: 1 of 1	Drawn By: WAS	Tolerances, unless otherwise noted Dec.: ±    Frac.: ±    Ang.: ±	Size: A
Scale: <b>NTS</b>	Approved By: JCW		Rev.: A
Dim.: Var.	Date: 12-OCT-18	Dwg. No.: SC2.00S11.01.0.0	